

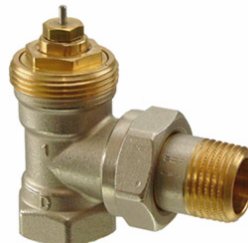

Straight valves VDN2...



Angle valves VEN2...



Reverse angle valves VUN2...



## Radiator Valves

NF norm, for 2-pipe heating systems

**VDN2...**  
**VEN2...**  
**VUN2...**

- Valve bodies made of brass, mat nickel-plated
- DN10, DN15 and DN20 (VDN2..., VEN2...)
- Integrated preadjustment of  $k_v$ -values
- Internally and externally threaded (Rp/R) conforming to ISO 7/1
- Manual knob / protective cover included in the delivery
- Can be combined with RTN... thermostatic actuators, SSA... motoric actuators or STA... thermal actuators, STS61 and electronic REH... radiator controllers

### Use

The radiator valves are used in hot water heating plant for individual room or zone temperature control and limitation. They are basically recommended in all rooms, especially where heat gains or different temperature levels occur.

## Type summary

Type reference straight	Type reference angle	Type reference reverse angle	DN	$k_v$ -value [ $m^3/h$ ] setting range	$k_v$ -value [ $m^3/h$ ] at a P-band of 2 K
VDN210	VEN210		10	0.09 ... 0.63	0.43
		VUN210		0.14 ... 0.60	
VDN215	VEN215		15	0.10 ... 0.89	0.52
		VUN215		0.13 ... 0.77	
VDN220	VEN220		20	0.31 ... 1.41	0.71

### Order

When ordering, please give quantity, product name and type reference.

Example: 2 straight valves VDN220

### Delivery

Valves and accessories are packed separately.

## Equipment combinations

Product	Types	Data sheet
Thermostatic actuators	RTN...	N2111
Electronic radiator controller	REH90	N2131
Motoric actuators	SSA31... / SSA61... / SSA81...	N4893
Thermal actuators	STA21 / STA71	N4877
Thermal actuator	STS61 <sup>1)</sup>	N4880

<sup>1)</sup> Quasi-proportional control action, not recommended for parallel operation

## Mechanical design / technical design

The flow rate can be preadjusted with an orifice. Full stroke is ensured irrespective of the preadjustment, which is made with the help of the protective cover.

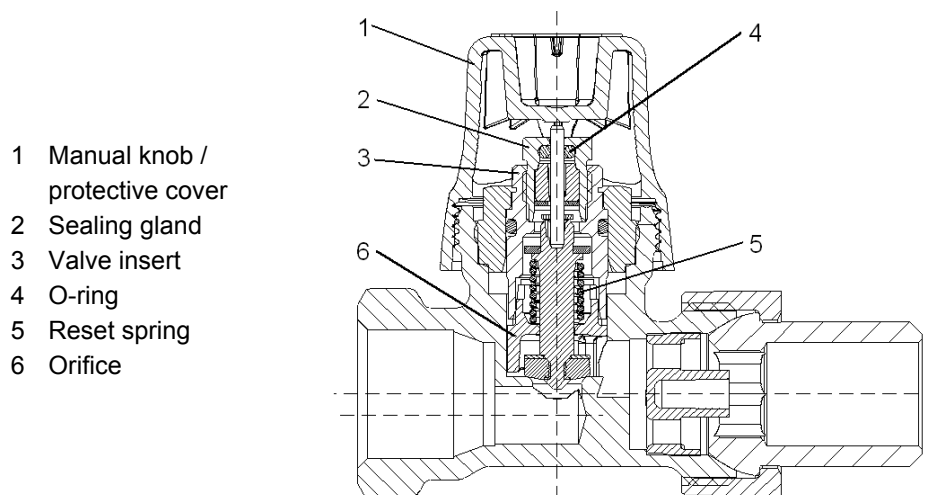

- 1 Manual knob / protective cover
- 2 Sealing gland
- 3 Valve insert
- 4 O-ring
- 5 Reset spring
- 6 Orifice

### Features and benefits

- The valves conform to EN 215
- The sealing gland can be replaced while the plant is under pressure (no tools required)

## Accessories

**AVN1**  
Sealing gland



**ATN2**  
Protection against dismantling



**ATN3**  
Manual knob  
(RAL9016)



**AVN...**  
Compression fittings



## Engineering notes

The reference numbers for preadjustment are given in the table with the  $k_v$ -values (see page 4) and in the valve sizing charts (see pages 5 – 7).

1. Calculate the volumetric water flow  $\dot{V}_{100}$

$$\dot{V}_{100} = \frac{Q_{100}}{1.163 \times \Delta T \times f_1} \quad [\text{m}^3/\text{h}]$$

$Q_{100}$  = heat demand [kW]  
 $\Delta T$  = temperature differential [K]  
 1.163 = constant of water  
 $f_1$  = correction factor = 1 for water

2. Define the pressure drop  $\Delta p_{v100}$  across the fully open valve

In most types of plant, a differential pressure  $\Delta p_{v100}$  of 0.05 to 0.2 bar is adequate.

3. Calculation of the nominal flow value  $k_v$

$$k_v = \frac{\dot{V}_{100}}{\sqrt{\Delta p_{v100}}} \quad [\text{m}^3/\text{h}]$$

$\Delta p_{v100}$  = differential pressure across the valve [bar]

Example:

Heat demand	$Q_{100}$	= 1.2 kW
Temperature differential	$\Delta T$	= 20 K
Water volume	$\dot{V}_{100} = \frac{1.2}{1.163 \times 20}$	= 0.052 m <sup>3</sup> /h = 52 l/h
Required differential pressure across the valve	$\Delta p_{v100}$	= 0.1 bar
Flow	$k_v = \frac{0.052}{\sqrt{0.1}}$	= 0.17 m <sup>3</sup> /h

### Solution

According to the chart (refer to «Valve sizing charts», or table with  $k_v$ -values), the preadjustment required for a VDN210 3/8" valve is 2.

### Tips

- Noiseless operation is ensured by a pump that provides no more pressure than is needed to transport the required amount of water
- To keep the valve free from dirt particles, it is recommended to install a strainer

## k<sub>v</sub>-values

The k<sub>v</sub>-value gives the volumetric water flow  $\dot{V}_{100}$  in m<sup>3</sup>/h at a pressure drop  $\Delta p_{v100}$  across the valve of 1 bar.

### k<sub>v</sub>-values [m<sup>3</sup>/h] at the different preset positions

Control range with SSA..., STA... actuators and STS 61	✓	✓	✓	✓	✓	✓	✗
Control range of thermostatic actuators RTN...	✓	✓	✓	✓	✓	✗	✓
<b>Reference numbers for preadjustment</b>	<b>1</b>	<b>2</b>	<b>3</b>	<b>4</b>	<b>5</b>	<b>N</b>	<b>N<sup>1)</sup></b>
VDN210 / VEN210	0.09	0.18	0.26	0.33	0.48	0.63	0.43
VDN215 / VEN215	0.10	0.20	0.31	0.45	0.69	0.89	0.52
VDN220 / VEN220	0.31	0.41	0.54	0.83	0.91	1.41	0.71
VUN210	0.14	0.28	0.38	0.49	0.53	0.60	0.43
VUN215	0.13	0.23	0.34	0.52	0.66	0.77	0.50

<sup>1)</sup> k<sub>v</sub>-value at a P-band of 2 K

## Setting the k<sub>v</sub>-value

The k<sub>v</sub>-values can be set on the valve's head in 5 steps + N (fully open) using the protective cover, which can be turned through 180°.



Observe marking on the valve's outlet side!

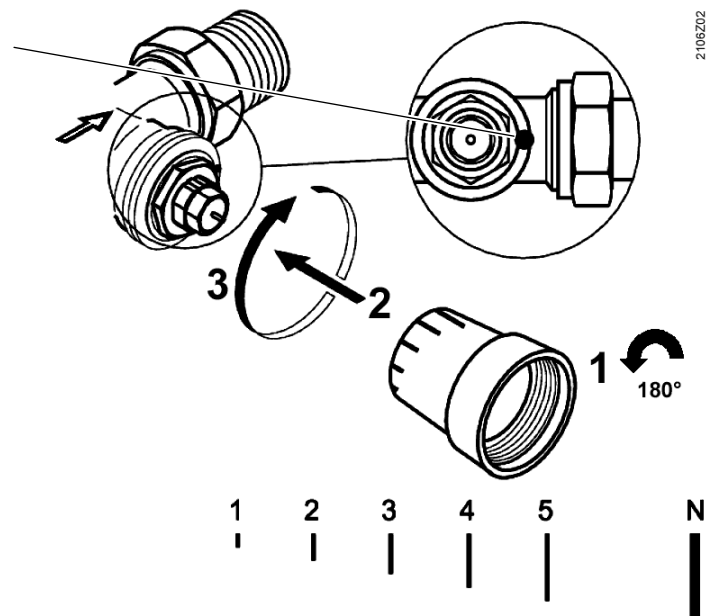

2106Z02

Valve sizing charts

VDN210  
VEN210

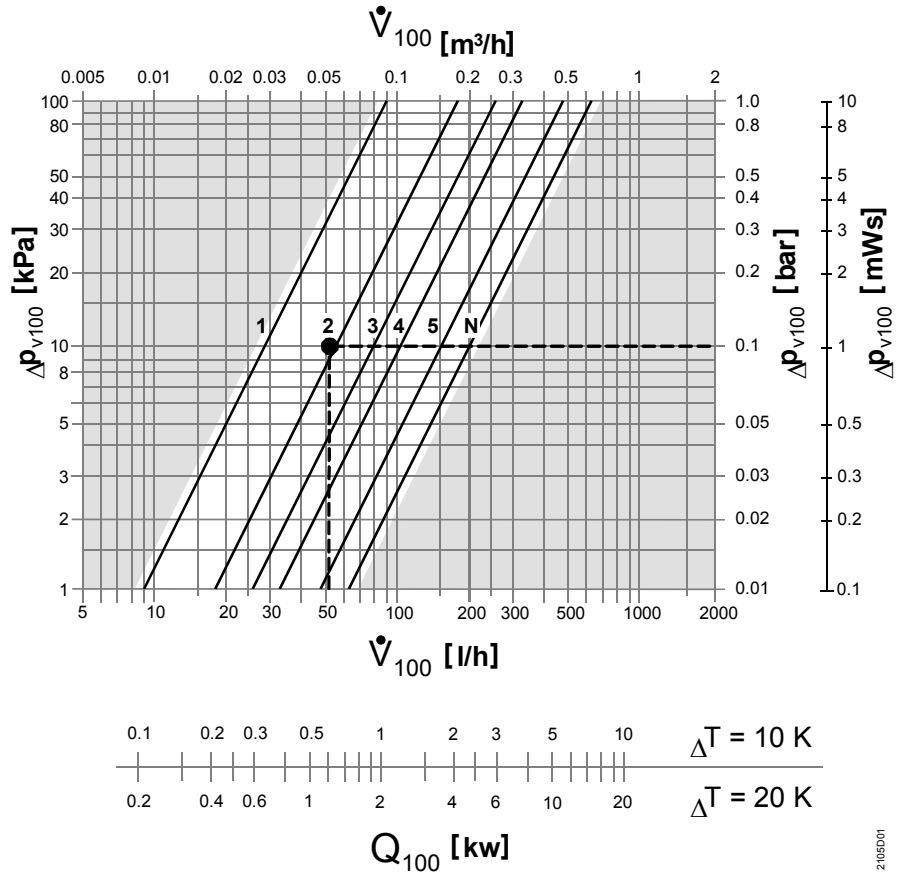

2105D01

VDN215  
VEN215

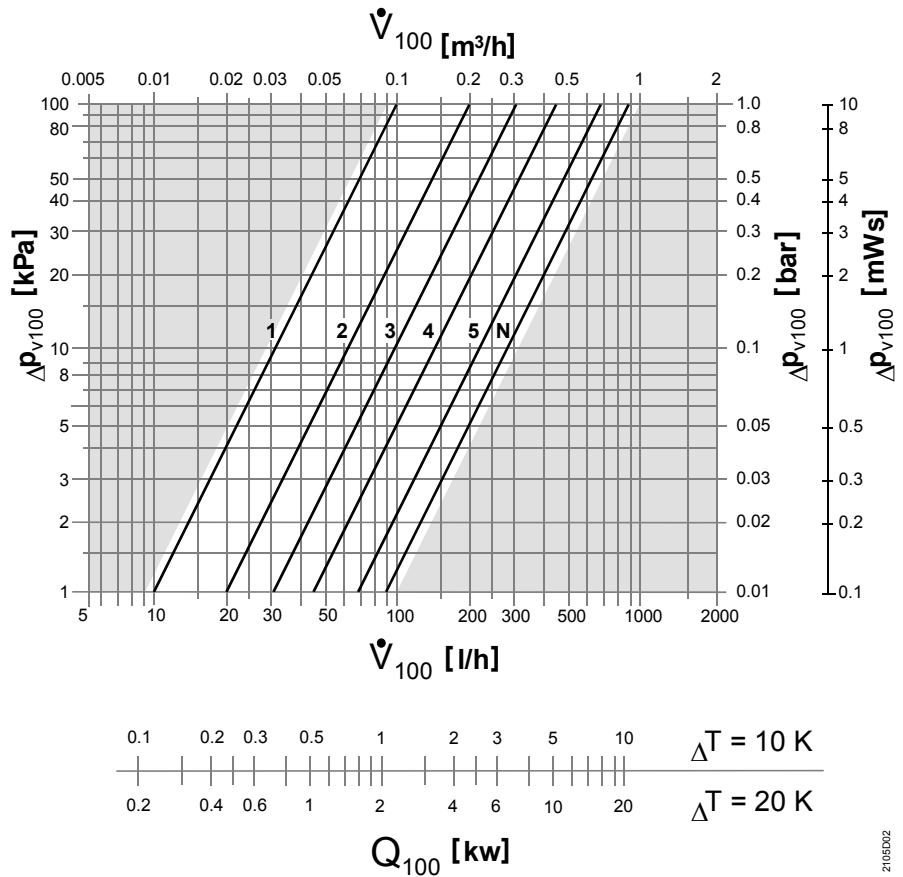

2105D02

**VDN220**  
**VEN220**

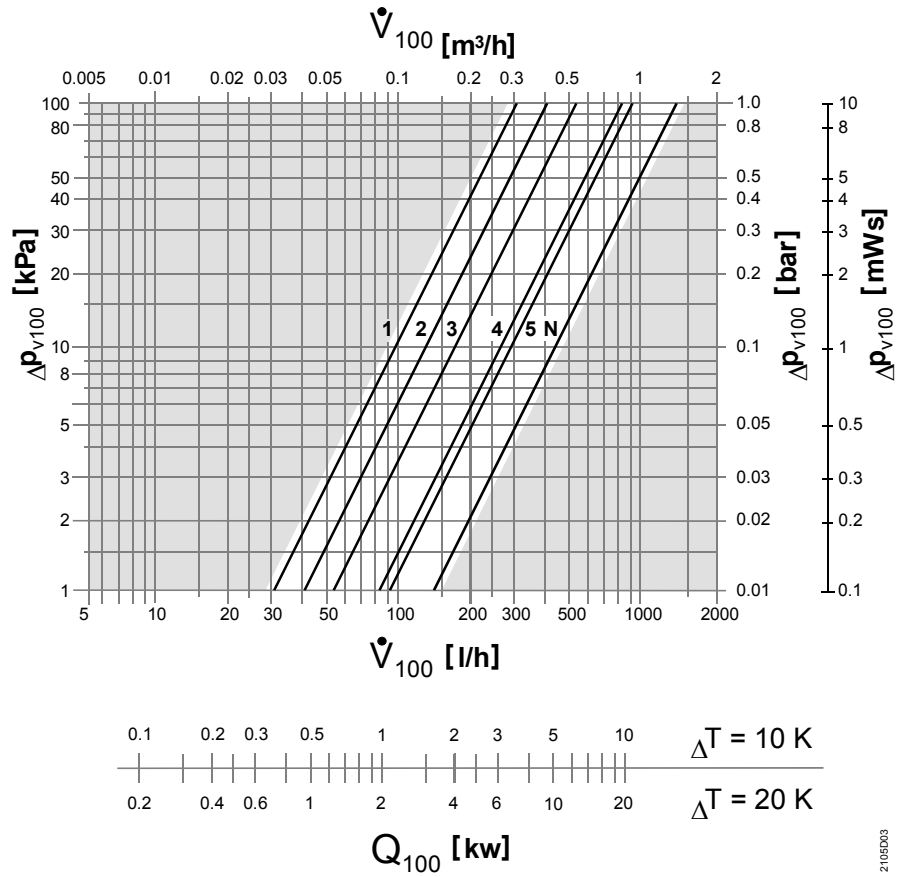

**VUN210**

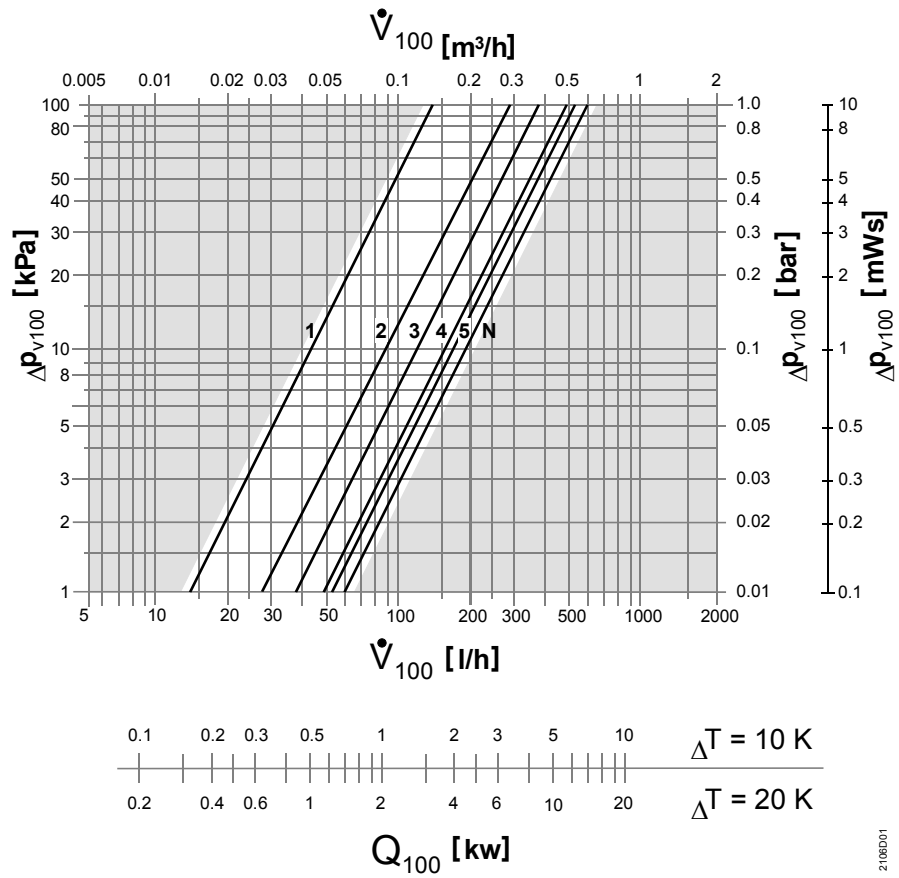

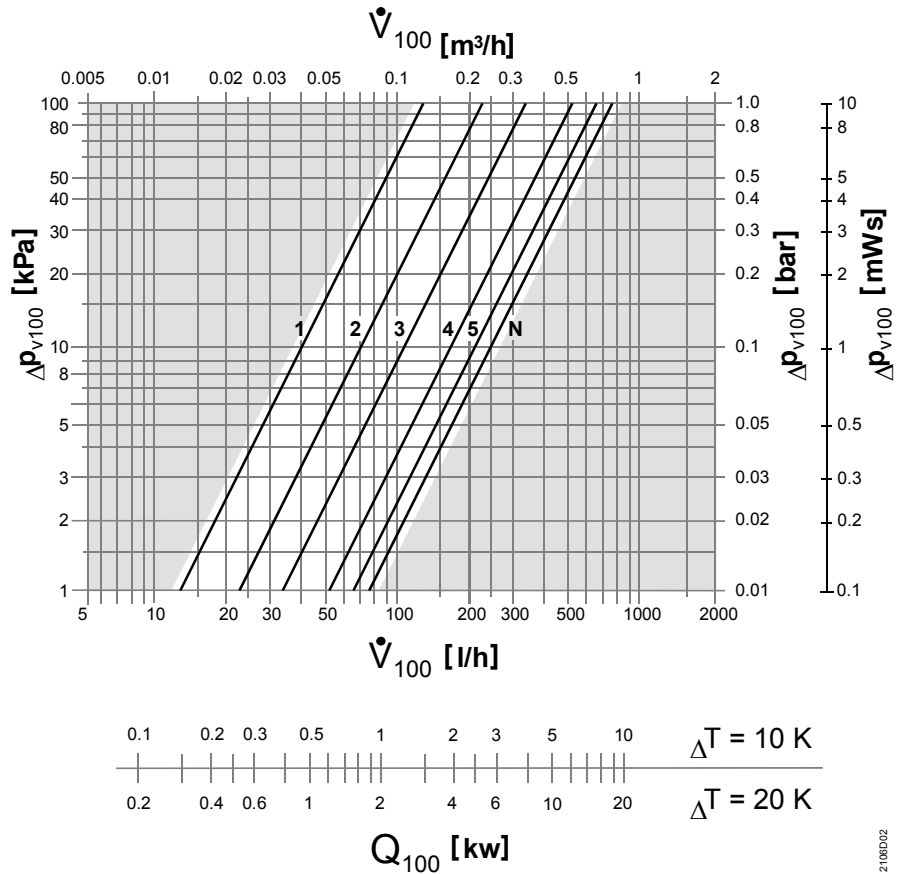

2106D02

**Notes**

**Mounting**

- Mounting Instructions are printed on the package
- The valves are supplied preadjusted to N (fully open)
- To ensure correct functioning of the thermostatic heads and electronic actuators, observe the available mounting choices and mounting conditions

**Orientation**

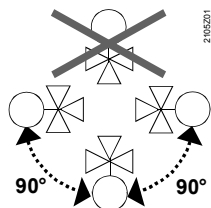

**Maintenance**

The valves are maintenance-free.

**Repair**

In the event of leakage, the valve's sealing gland can be replaced. The valves cannot be repaired; the complete unit must be replaced.

**Disposal**



The valve must not be disposed of together with domestic waste. Legislation may demand special handling of certain components, or it may be sensible from an ecological point of view.

**Current local legislation must be observed.**

**Warranty**

Application-related technical data are only warranted when used in connection with the Siemens controllers and actuators listed under «Equipment combinations».

**When using the radiator valves with actuators of other manufacture, any warranty by Siemens Switzerland Ltd / HVAC Products becomes void.**

## Technical data

<b>Functional data</b>	PN class	PN 10		
	Suitable media	cold and hot water, water-glycol mixtures; recommendation: water treatment to VDI 2035		
	Medium temperature	1 ... 120 °C		
	Perm. operating pressure	1000 kPa (10 bar)		
	Differential pressure $\Delta p_{max}$	max. 60 kPa (0.6 bar)		
	Differential pressure $\Delta p_{V100}$	5 ... 20 kPa (0.05 ... 0.2 bar): recommended range		
	Stroke	min 1.2 mm		
<b>Materials</b>	Valve body	brass, mat nickel-plated		
	Fitting	brass, mat nickel-plated		
	Protective cover	polypropylene		
	O-ring	EPDM		
<b>Dimensions / weight</b>	Refer to «Dimensions»			
	Mounting length	EN 215		
	Thread	Rp internally threaded	to ISO 7/1	
		R externally threaded	to ISO 7/1	
G-thread		to ISO 228/1		

## Dimensions

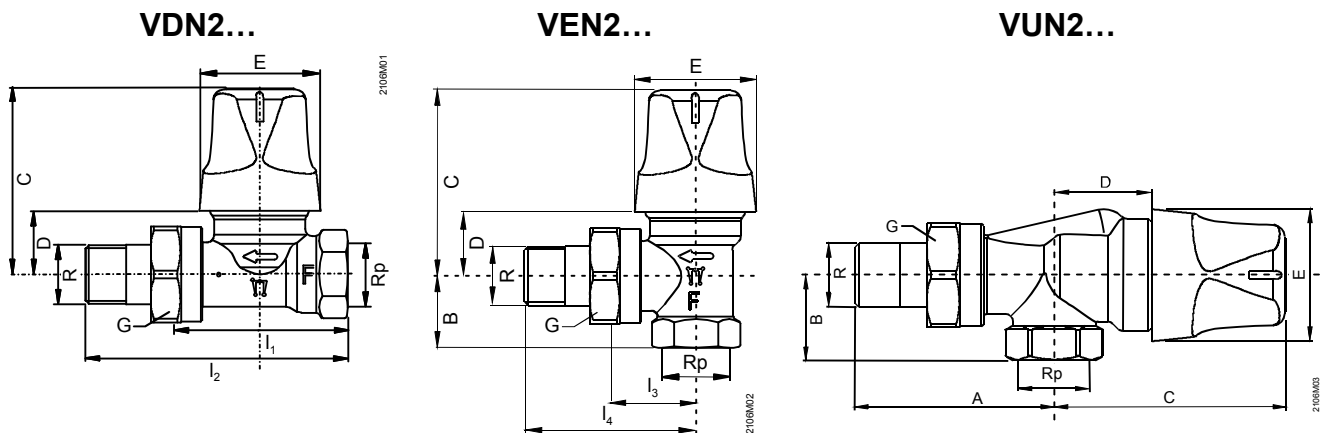

Type	DN	Dimensions [mm]								Thread [inch]			Weight [kg]	
		I <sub>1</sub>	I <sub>2</sub>	I <sub>3</sub>	I <sub>4</sub>	A	B	C	D	E	Rp	R		G
VDN210	10	50	75					53	18	35	3/8	3/8B	5/8	0.220
VDN215	15	55	82					53	18	35	1/2	1/2B	3/4	0.265
VDN220	20	65	98					53	18	35	3/4	3/4B	1	0.385
VEN210	10			24	49		20	53	18	35	3/8	3/8B	5/8	0.215
VEN215	15			26	53		23	53	18	35	1/2	1/2B	3/4	0.260
VEN220	20			30	63		26	53	18	35	3/4	3/4B	1	0.360
VUN210	10					51	22	60	25	35	3/8	3/8B	5/8	0.285
VUN215	15					57	27	61	26	35	1/2	1/2B	3/4	0.330