

## Two-port seat valves with flange, PN40

### VVF61...



DN15 and DN25



DN40 ... DN150

### Two-port seat valves with flange, PN40

- DN15 ... DN150 mm
- DN15 and DN25: cast steel GS-C 25 N
- DN40 ... DN150: cast steel GS-45
- $k_{vs}$  0.19 ... 300
- Stroke 20 or 40 mm
- Can be equipped with actuators SQX..., SKD... and SKB...

### Use

For use in district heating, heating, ventilating, and air conditioning systems as a control or safety shutoff valve as per DIN 32730. For open and closed circuits.

### Media

#### Standard versions with standard stem sealing gland for:

<b>Cooling water</b> <b>Chilled water</b> <b>Low temperature hot water</b> <b>High temperature hot water</b> <b>Water with anti-freeze</b> <sup>1) 2)</sup>	-25 ... +220 °C
<b>Saturated steam/super-heated steam</b> <b>DN15 and 25</b> (up to max. 17 bar abs.) <b>DN40...150</b> (up to max. 11 bar abs.) <b>Brine</b> <sup>1) 2)</sup>	

#### Special versions with thermal insulator and special stem sealing gland for:

<b>Thermo oils</b>	220 ... 300/350 °C <sup>3)</sup>
<b>Refrigerants</b>	not permissible <sup>4)</sup>

- 1) Media below 0 °C: ASZ6.5 stem heating element required to prevent freezing of the valve stem in the sealing gland.
- 2) Water with anti-freeze and brine: down to -10 °C as per DIN 3158 (stress case I) or down to -25 °C as per DIN 3158 (stress case II)
- 3) For applications with thermo oils of 220 ... 300 / 350 °C, a thermal insulator between the valve and the actuator is required.  
The maximum permissible temperatures in dependence of valve body material are described in the sections "Notes" and "Engineering notes".
- 4) For these applications, special refrigerant valves with magnetic actuators are used; refer to data sheets 4700 ... 4799

## Type summary

Standard version				
Type	DN [mm]	$k_{vs}$ [m <sup>3</sup> /h]	$S_v$	$\Delta p_{vmax.}$ [kPa]
VVF61.09	15/1	0.19	>50	1600
VVF61.10	15/1.5	0.3		
VVF61.11	15/2.5	0.45		
VVF61.12	15/4	0.7		
VVF61.13	15/6	1.2		
VVF61.14	15/10	1.9		
VVF61.15	15	3		
VVF61.23	25/15	3	>100	1000
VVF61.24	25/20	5		
VVF61.25	25	7.5		
VVF61.39	40/32	12	>50	700
VVF61.40	40	19	>100	450
VVF61.50	50	31		
VVF61.65	65	49		
VVF61.80	80	78		
VVF61.90	100	124		
VVF61.91	125	200		
VVF61.92	150	300		300
				200

### Special versions with type suffix 2

For media and temperatures:		Example:
Thermo oils	220 ... 300 / 350 °C	VVF61.502 <sup>1)</sup>

1) **Thermal insulator** for special version (type suffix: 2), required for thermo oils from 220 °C to max. 300/350 °C; factory-mounted in the valve on delivery.

DN = Nominal diameter

$k_{vs}$  = Nominal flow value as per VDI 2173

$S_v$  = Rangeability as per VDI 2173

$\Delta p_{vmax.}$  = Max. permissible differential pressure across the valve's control path, valid for the entire stroke range

### Accessories

**Electric stem heating element**, AC 24 V, required for media below 0 °C : **ASZ6.5**

### Ordering

When ordering, please indicate type reference and type suffix (where required).

Example: **VVF61.50**

### Delivery

Both the valve and the actuator are packed and supplied separately.

The special version (type suffix: 2) for thermo oils is delivered with factory-mounted thermal insulator in the valve.

The valves are supplied without counter-flanges and without flange gaskets.

## Equipment combinations

Valves	$H_{100}$ [mm]	Actuators <sup>1)</sup>					
		SKD... <sup>2)</sup>		SKB...		SKC...	
		$\Delta p_{max}$	$\Delta p_s$	$\Delta p_{max}$	$\Delta p_s$	$\Delta p_{max}$	$\Delta p_s$
VVF61.09 ... VVF61.15	20	1600	4000	1600	4000		
VVF61.23 ... VVF61.25			2250				
VVF61.39 ... VVF61.40							
VVF61.50							
VVF61.65	40					1000	4000
VVF61.80						700	
VVF61.90						450	
VVF61.91						300	
VVF61.92						200	
<b>Data sheet</b>		<b>4561</b>		<b>4564</b>			

- 1) Actuators available for delivery:
    - AC 24 V / AC 230 V with 3-position signal
    - AC 24 V with proportional pos. signal DC 0...10 V or DC 4...20 mA
  - 2) Usable up to max. medium temperature of 140 °C
- $H_{100}$  = 100 % stroke of the valve and the actuator  
 $\Delta p_{max}$  = Max. permissible differential pressure across the valve's control path across the entire actuating range of the motorized valve  
 $\Delta p_s$  = Maximum permissible differential pressure (closing pressure) at which the motorized valve will close securely against pressure.

### Pneumatic actuators

- DN15 and DN25 can also be used with pneumatic actuators.
- For DN40 ... DN150, use of pneumatic actuators is possible only if the direction of flow counters the direction of the arrow (inverted flow direction.)  
 For  $\Delta p_{max}$  and  $\Delta p_s$  the values as listed in the data sheet for the VVF41... (4340) are valid.
- Contact your local office or branch for more information.

---

## Mechanical design

### Valve cross sections

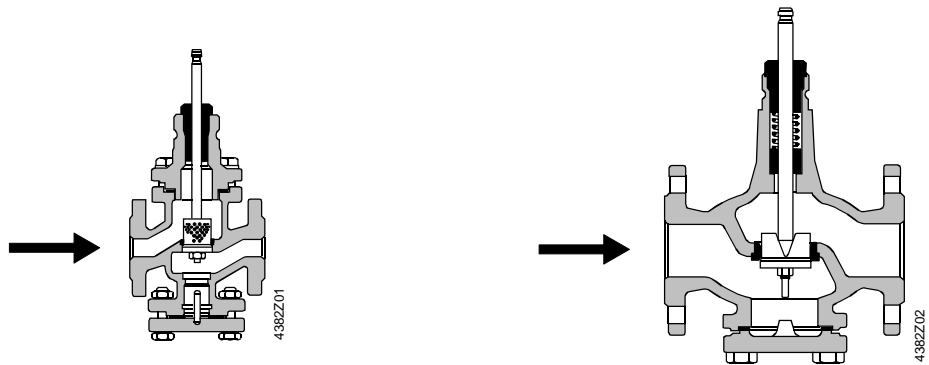

DN15 and DN25  
closes against pressure

DN40 ... DN150  
closes on pressure

Depending on the nominal size, a guided parabolic, perforated or slot plug is used that is directly connected to the valve stem.

The seat is screwed to the valve body with the aid of special gland material.



**The two-port seat valve does not become a three-port valve by removing the blank flange.**

### Thermal insulator

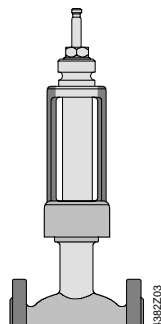

**Thermal insulator** for special version (type suffix: **2**), required for thermo oils from 220 °C to 300 / 350 °C; factory-mounted in the valve on delivery.

### Disposal

The various material types used require that you disassemble the unit and sort the components prior to disposal.

# Sizing

## Flow diagram

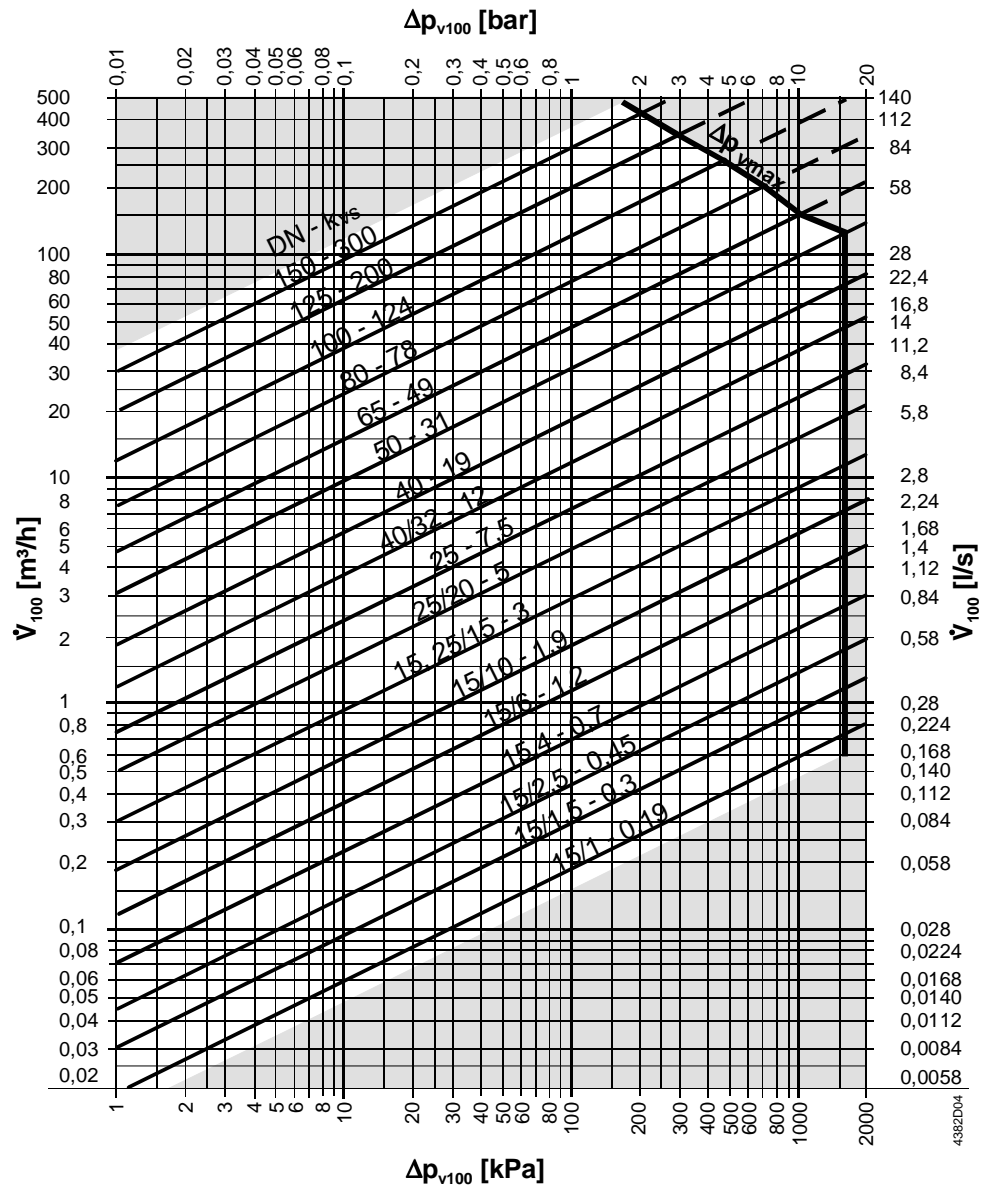

$\Delta p_{vmax}$  = Maximum permissible differential pressure across the valve's control path, valid for the entire stroke range

$\Delta p_{v100}$  = Differential pressure across the fully opened valve across the control path at flow  $\dot{V}_{100}$  in kPa or in bar

$\dot{V}_{100}$  = Flow in m<sup>3</sup>/h or in l/s

100 kPa = 1 bar  $\approx$  10 mWG

## Valve flow characteristic

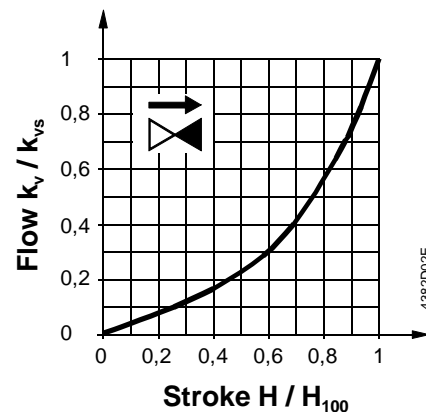

### Valve flow characteristic

0 ... 30 %  $\Rightarrow$  linear

30 ... 100 %  $\Rightarrow n_{gl} = 3$  as per VDI / VDE 2173

## Working pressure and temperature

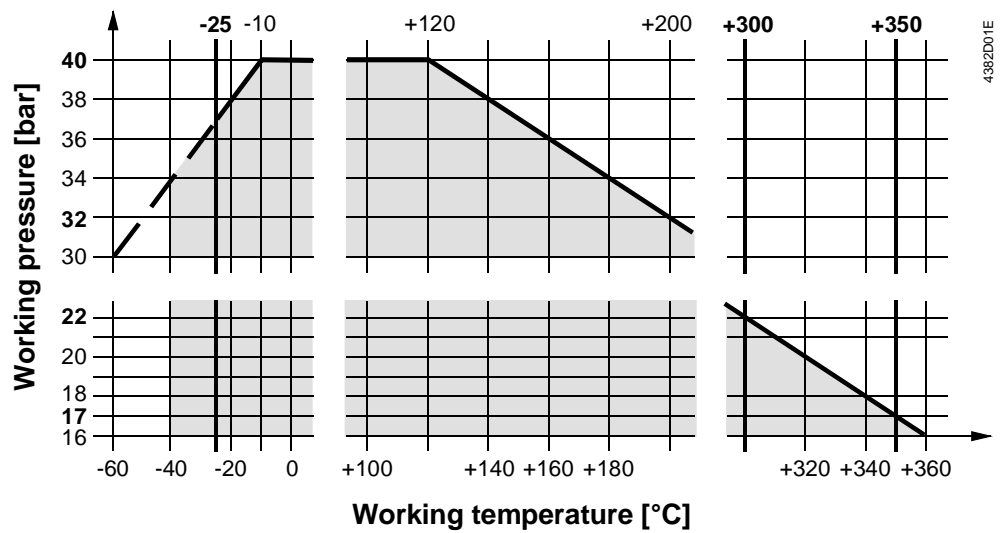

Working pressure staged as per ISO 7268 and EN 1333  
at operating temperatures of  $-25 \dots +300/+350 \text{ }^{\circ}\text{C}$  as per DIN 4747 and DIN 3158.

## Notes Engineering

We recommend installation in the return pipe, as the temperatures in this pipe are lower for applications in heating systems, which in turn, extends the stem sealing gland's life.  
**Water quality requirements as per VDI 2035.**

 **In open circuits**, there is a risk of valve plug seizing caused by scale deposits. Thus, use only the most powerful actuators SKB... or SKC... for these applications. Additionally, periodic actuation (twice or three times per week) must be planned.  
**Always use a strainer** upstream of the valve.

We generally recommend that you install a **strainer even with closed circuits** to increase the valve's functional safety.

 **For media below  $0 \text{ }^{\circ}\text{C}$** , use the electric **ASZ6.5 stem heating element** to prevent the valve stem from freezing in the sealing gland. For safety reasons, the stem heating element has been designed for **AC 24 V / 30 W** operating voltage.

 **The maximum permissible temperatures in dependence of valve body materials are:**  
 – GS-C 25 N = max.  $350 \text{ }^{\circ}\text{C}$  (DN15 and DN25)  
 – GS-45 = max.  $300 \text{ }^{\circ}\text{C}$  (DN40 ... DN150)

## Mounting

Both valve and actuator can easily be assembled at the mounting location. Neither special tools nor adjustments are required.

The thermal insulator for thermo oil applications is factory-mounted for type suffix **2**. The actuator is directly mounted on the thermal insulator instead of the valve. The valve is supplied with mounting instructions.

## Mounting positions

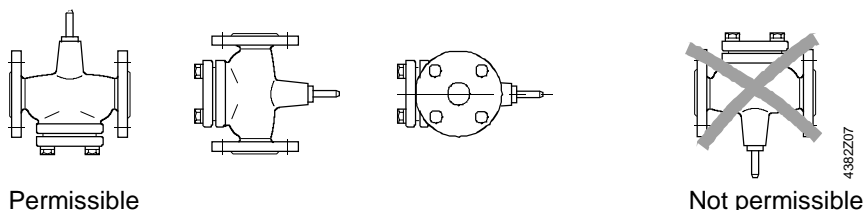

Permissible

Not permissible

## Direction of flow

When mounting, pay attention to the **valve's flow direction symbol** .

**Commissioning**  **Commission the valve only if the actuator has been mounted correctly.**

Stem retracts: Increasing flow  
Stem extends: Decreasing flow

**Service**  **For actuator service work: Turn off the pump and the operating voltage, close the shutoff valves, depressurize the pipes and allow them to cool down. Disconnect the electrical connections, where required, from the terminals. Re-commission the valve only if the actuator has been mounted correctly.**

**Stem sealing gland** The glands can be exchanged without removing the valve, provided the pipes are depressurized and cooled off and the stem surface is unharmed. If the stem is damaged in the gland range, replace the entire stem-plug-unit. Contact your local office or branch.

### Spare parts

DN15 and DN25:  
Standard version  
DN15 ... DN150:  
Special version 2

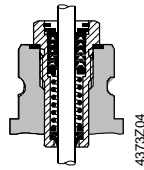

Replacement for PTFE-O-ring sealing gland, including flat seal made from copper, for cooling water, chilled water, low temperature hot water, high temperature hot water, saturated steam, super-heated steam, thermo oils and brine  $-25 \dots +300/+350 \text{ }^\circ\text{C}$

For VVF61... DN15 and DN25 (Stem dia. 10 mm) **4 284 8829 0**  
For VVF61 ... 2 DN15 ... DN150 (Stem dia. 10 mm) **4 284 8829 0**

DN40 ... DN150:  
Standard version

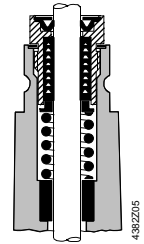

Replacement for PTFE-O-ring sealing gland, including flat seal made from copper, for cooling water, chilled water, low temperature hot water, high temperature hot water, saturated steam, super-heated steam and brine  $-25 \dots +220 \text{ }^\circ\text{C}$

For VVF61... DN40 ... DN150 (Stem dia. 14 mm) **4 679 5630 0**

### Warranty

**The use of third-party actuators expressly voids any warranty claims.**

The technical data  $\Delta p_{\max}$ ,  $\Delta p_s$ , leakage rate, noise level and life apply only when used together with the Landis & Staefa actuators as listed in "Type summary".

---

## Technical data

### Function data

PN class	PN40
Valve flow characteristic	linear
0 ... 30 %	$n_{gl} = 3$ as per VDI / VDE 2173
30 ... 100 %	0 ... 0.02 % of $k_{vs}$ value, VDE / VDI 2173
Leakage rate	4000 kPa (40 bar), ISO 7268 / EN 1333
Permissible pressure	DIN 4747 / DIN 3158 in the range of -25...+300/350 °C
Working pressure	ISO 7005
Flange connections	
Stroke	
- DN15 ... DN50	20 mm
- DN65 ... DN150	40 mm

### Materials

Valve body	Cast steel
DN15 and DN25	GS-C 25 N as per DIN 17245
DN40 ... DN150	GS-45 as per DIN 1681
Seat, plug, and stem	stainless steel
Sealing gland	
Standard version	stainless steel
Special version	stainless steel
Gland materials	PTFE sleeves

## Dimensions

All dimensions in mm

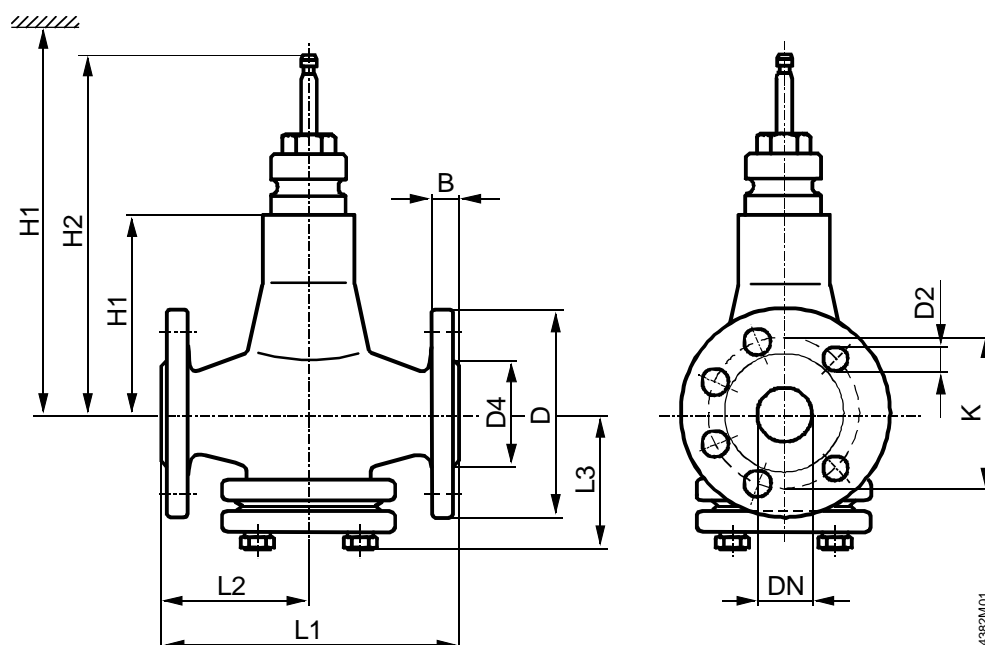

DN [mm]	B	D dia.	D2 dia.	D4 dia.	H1	H2	K	L1	L2	L3	Weight [kg]
15	14	95	14 (4x)	46	96	192.5	65	130	65	90	5.7
25	16	115	14 (4x)	65	111	207.5	85	160	80	107	9.0
40	18	150	18 (4x)	84	136	232.5	110	200	100	102	14.8
50	20	165	18 (4x)	99	136	232.5	125	230	115	107	17.5
65	22	185	18 (8x)	118	162	278.5	145	290	145	138	30.0
80	24	200	18 (8x)	132	170	286.5	160	310	155	150	37.0
100	24	235	22 (8x)	156	180	296.5	190	350	175	173	53.0
125	26	270	26 (8x)	184	200	316.5	220	400	200	195	76.0
150	28	300	26 (8x)	211	225	341.5	250	480	240	219	112.0

DN [mm]	SKD...	H SKB...	SKC...
15	> 596	> 671	
25	> 611	> 686	
40	> 636	> 711	
50	> 636	> 711	
65			> 737
80			> 745
100			> 755
125			> 775
150			> 800

DN = Nominal diameter

H = Total actuator height plus minimum distance to the wall or the ceiling for mounting, connection, operation, service, etc.

H1 = Dimension from the pipe centre to install Structure the actuator (upper edge)

H2 = Valve in the "Closed" position means that the stem is fully extended